

1. Five To Go

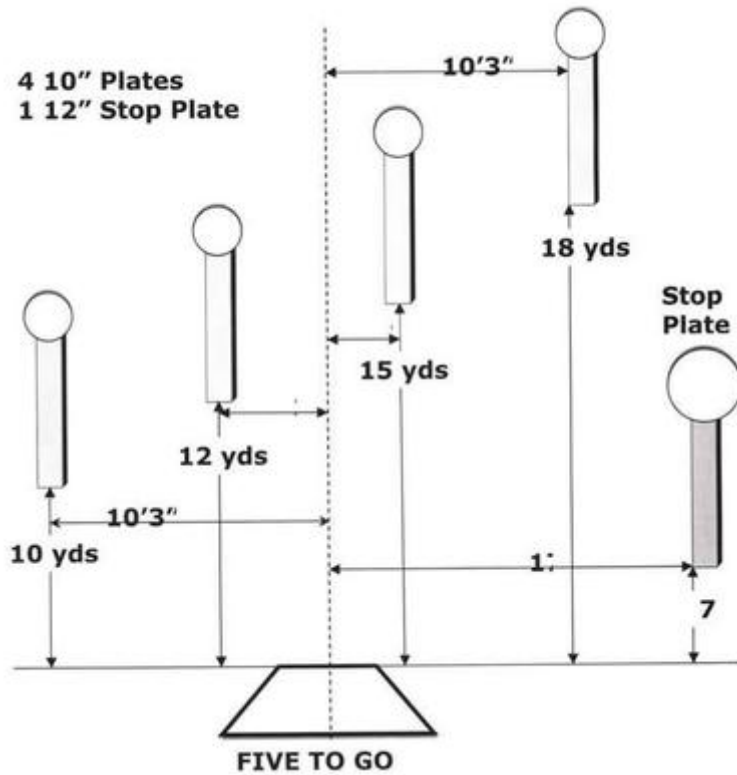

Scoring	sound	Strings	The best 4 of 5 will be counted
Distance	21 feet to stop plate	Min rounds	25
Correction	0 sec		-

Procedure	
Starting position	
Start on	
Stop on	
Penalties	
Safety angles	L/R
Setup notes	

3. Roundabout

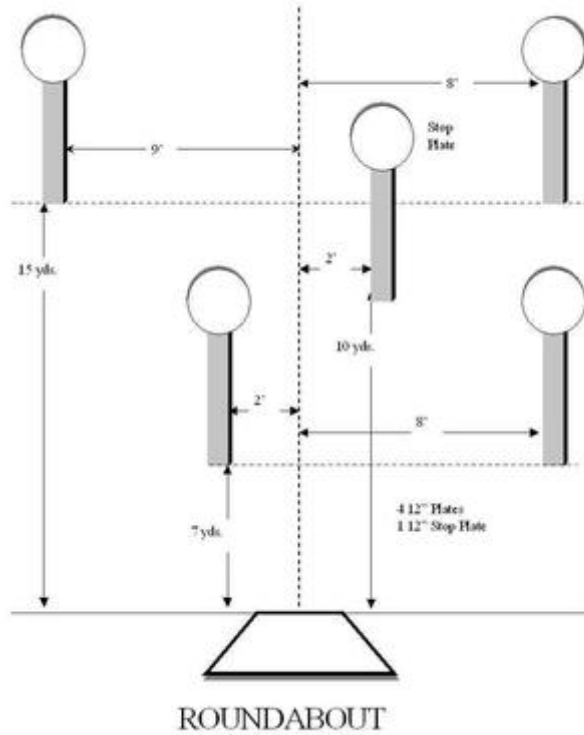

Scoring	sound	Strings	The best 4 of 5 will be counted
Distance	30 feet to stop plate	Min rounds	25
Correction	0 sec		-

Procedure	
Starting position	
Start on	
Stop on	
Penalties	
Safety angles	L/R
Setup notes	

4. Showdown

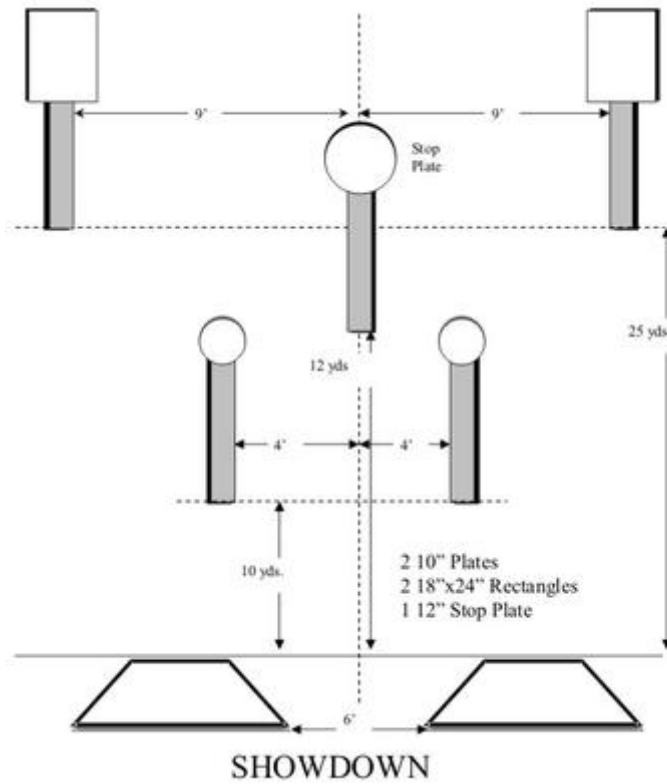

Scoring	sound	Strings	The best 4 of 5 will be counted
Distance	36 feet to stop plate	Min rounds	25
Correction	0 sec		-

Procedure	
Starting position	
Start on	
Stop on	
Penalties	
Safety angles	L/R
Setup notes	

5. Smoke & Hope

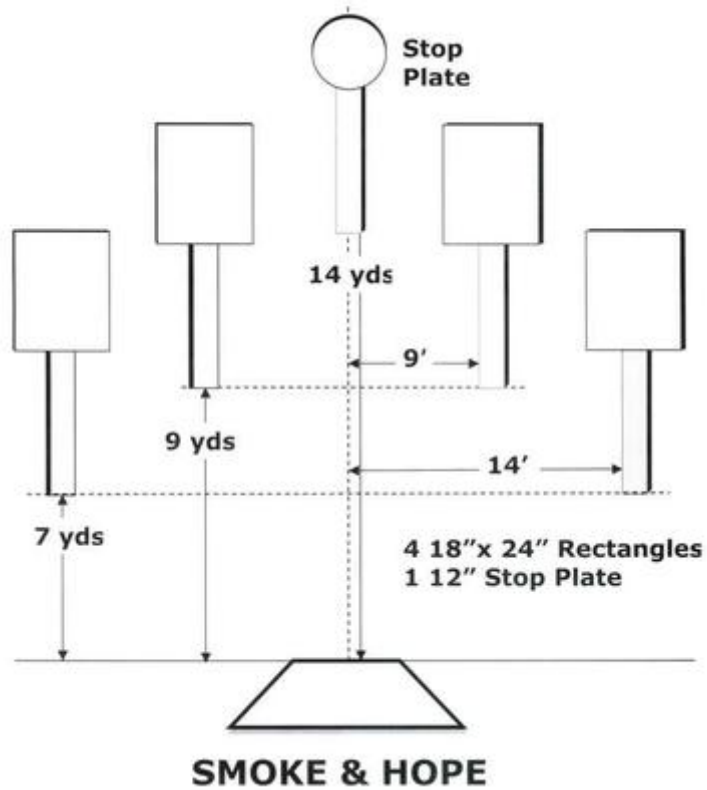

Scoring	sound	Strings	The best 4 of 5 will be counted
Distance	42 feet to stop plate	Min rounds	25
Correction	0 sec		-

Procedure	
Starting position	
Start on	
Stop on	
Penalties	
Safety angles	L/R
Setup notes	

7. Pendulum

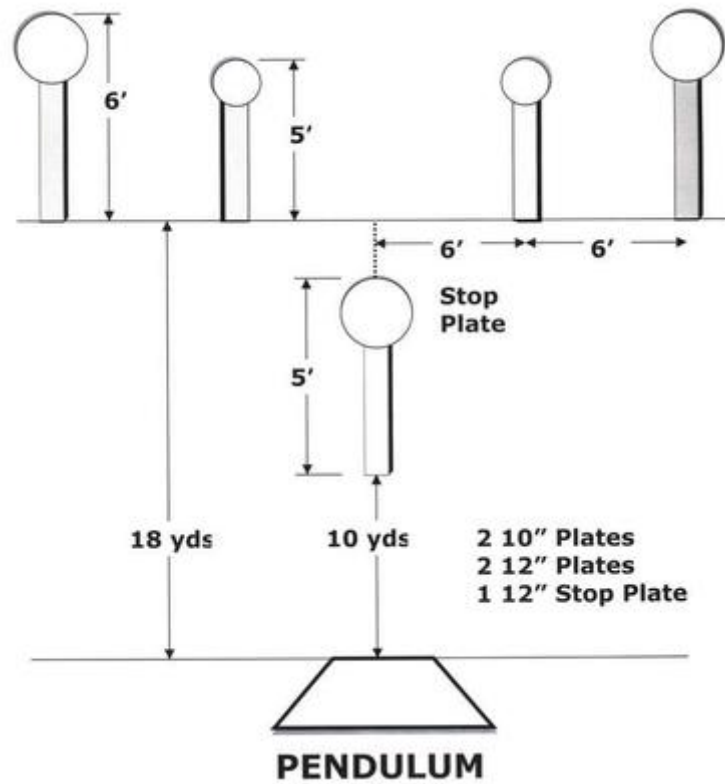

Scoring	sound	Strings	The best 4 of 5 will be counted
Distance	30 feet to stop plate	Min rounds	25
Correction	0 sec		-

Procedure	
Starting position	
Start on	
Stop on	
Penalties	
Safety angles	L/R
Setup notes	

8. Accelerator

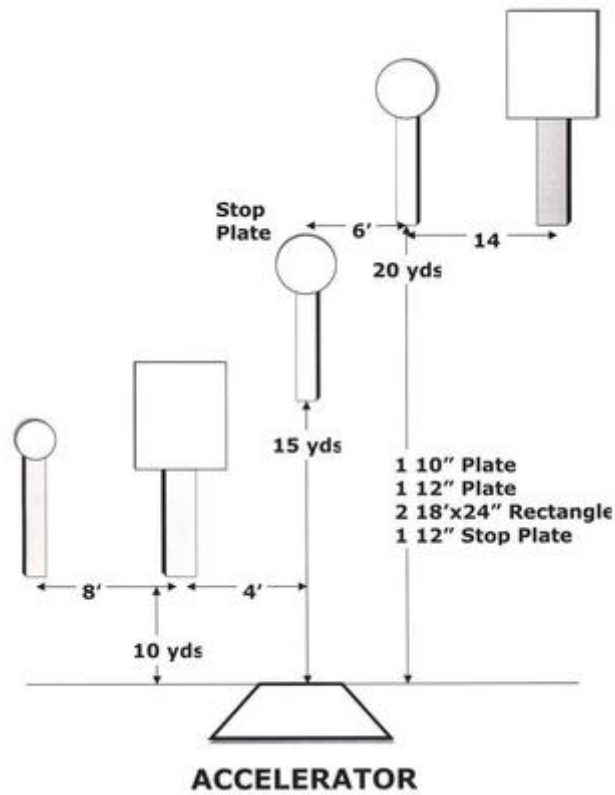

Scoring	sound	Strings	The best 4 of 5 will be counted
Distance	45 feet to stop plate	Min rounds	25
Correction	0 sec		-

Procedure	
Starting position	
Start on	
Stop on	
Penalties	
Safety angles	L/R
Setup notes	